



中国认可  
国际互认  
检测  
TESTING  
CNAS L6478



# TEST REPORT

**Reference No.**..... : WTF24F10236940E

**Applicant**..... : Guangzhou Aimei Intelligent Technology Co., Ltd.

**Address**..... : Floor 2, building B, No. 185, Zhongsheng Road, Zhongcun street,  
Panyu District, Guangzhou

**Manufacturer** ..... : The same as above

**Address**..... : The same as above

**Product Name**..... : Hair clipper

**Model No.**..... : HC-W058, HC-W056, HC-W052, HC-W037, HC-W030, HC-W012,  
HC-W003A, TS7800, HC-W050, HC-W051, HC-W018, HC-W017,  
HC-W059, HC-W031, HC-W028, HC-W029, HC-W053

**Test specification**..... : EN IEC 55014-1:2021  
EN IEC 55014-2:2021

**Date of Receipt sample** .... : 2024-10-18

**Date of Test** ..... : 2024-10-18 to 2024-10-21

**Date of Issue**..... : 2024-10-28

**Test Report Form No.**..... : WEH-55014A-03C

**Test Result**..... : **Pass**

**Remarks:**

The results shown in this test report refer only to the sample(s) tested, this test report cannot be reproduced, except in full, without prior written permission of the company. The report would be invalid without specific stamp of test institute and the signatures of approver.

**Prepared By:**

**Waltek Testing Group (Foshan) Co., Ltd.**

Address: 1/F., Building 19, Sunlink Machinery City, Xingye 4 Road,  
Guanglong Industrial Park, Chihua Neighborhood Committee, Chencun Town,  
Shunde District, Foshan, Guangdong, China

Tel:+86-757-23811398 Fax:+86-757-23811381 E-mail:info@waltek.com.cn

Tested by:

*Jess Chen*

Jess Chen

Approved by:

*Danny Zhou*

Danny Zhou



## 1 Test Summary

EMISSION				
Test Item	Test Standard	Class / Severity	Result	
Mains Terminal Disturbance Voltage, 150kHz to 30MHz	EN IEC 55014-1:2021	Clause 4.3.3.6	Pass	
Disturbance Power, 30MHz to 300MHz	EN IEC 55014-1:2021	Clause 4.3.4.4	N/A	
Discontinuous Disturbance (Click)	EN IEC 55014-1:2021	Clause 4.4.2	N/A**	
Radiated Disturbance, 30MHz to 1000MHz	EN IEC 55014-1:2021	Clause 4.3.4.5	Pass	
IMMUNITY (EN IEC 55014-2:2021)				
Test Item	Test Method	Class / Severity	Performance Criteria	Result
Electrostatic Discharge(ESD)	IEC 61000-4-2:2008	±4 kV Contact ±8 kV Air	B	Pass
Radio-frequency electromagnetic fields (80MHz to 1GHz)	IEC 61000-4-3:2006+A1:2007+A2:2010	3V/m, 80%, 1kHz, Amp. Mod.	A	Pass
Electrical Fast Transients (EFT)	IEC 61000-4-4:2012	AC ±1.0kV DC ±0.5kV	B	Pass
Surge	IEC 61000-4-5:2014+A1:2017	±1kV D.M.† ±2kV C.M.‡	B	Pass
Injected Currents, 0.15MHz to 230MHz	IEC 61000-4-6:2013	3Vr.m.s.(emf), 80%, 1kHz Amp. Mod.	A	Pass
Voltage Dips and Interruptions	IEC 61000-4-11:2020	0 % U <sub>T</sub> * for 0.5per	C	Pass
		40 % U <sub>T</sub> * for 10per		Pass
		70 % U <sub>T</sub> * for 25per		Pass

### Remark:

Pass Test item meets the requirement

Fail Test item does not meet the requirement

N/A Test case does not apply to the test object

A.M Amplitude Modulation

† Differential Mode

‡ Common Mode

\* U<sub>T</sub> is the nominal supply voltage

\*\* According to the electrical characteristics and usage of the equipment, the EUT does not produce discontinuous radio interference voltages on AC Mains. Therefore this test item has been skipped.



## 2 Contents

	Page
<b>COVER PAGE</b> .....	<b>1</b>
<b>1 TEST SUMMARY</b> .....	<b>2</b>
<b>2 CONTENTS</b> .....	<b>3</b>
<b>3 GENERAL INFORMATION</b> .....	<b>5</b>
3.1 GENERAL DESCRIPTION OF E.U.T. ....	5
3.2 DETAILS OF E.U.T. ....	5
3.3 DESCRIPTION OF SUPPORT UNITS .....	5
3.4 STANDARDS APPLICABLE FOR TESTING.....	5
3.5 TEST FACILITY.....	6
3.6 SUBCONTRACTED.....	6
3.7 ABNORMALITIES FROM STANDARD CONDITIONS.....	6
<b>4 EQUIPMENT USED DURING TEST</b> .....	<b>7</b>
4.1 SOFTWARE LIST .....	9
4.2 MEASUREMENT UNCERTAINTY .....	9
4.3 SPECIAL ACCESSORIES AND AUXILIARY EQUIPMENT .....	9
4.4 DECISION RULE.....	9
<b>5 EMISSION TEST RESULTS</b> .....	<b>10</b>
5.1 MAINS TERMINALS DISTURBANCE VOLTAGE, 150KHZ TO 30MHZ .....	10
5.1.1 <i>E.U.T. Operation</i> .....	10
5.1.2 <i>Block Diagram of Test Setup</i> .....	10
5.1.3 <i>Measurement Data</i> .....	10
5.1.4 <i>Corrected Amplitude &amp; Margin Calculation</i> .....	11
5.1.5 <i>Mains Terminals Disturbance Voltage Test Data</i> .....	11
5.2 RADIATED DISTURBANCE, 30MHZ TO 1GHZ.....	13
5.2.1 <i>E.U.T. Operation</i> .....	13
5.2.2 <i>Block Diagram of Test Setup</i> .....	13
5.2.3 <i>Measurement Data</i> .....	13
5.2.4 <i>Corrected Amplitude &amp; Margin Calculation</i> .....	14
5.2.5 <i>Radiated Disturbance Test Data</i> .....	14
<b>6 IMMUNITY TEST RESULTS</b> .....	<b>18</b>
6.1 PERFORMANCE CRITERIA .....	18
6.2 ELECTROSTATIC DISCHARGE (ESD).....	19
6.2.1 <i>E.U.T. Operation</i> .....	19
6.2.2 <i>Block Diagram of Setup</i> .....	19
6.2.3 <i>Direct Discharge Test Results</i> .....	20
6.2.4 <i>Indirect Discharge Test Results</i> .....	20
6.3 RADIO-FREQUENCY ELECTROMAGNETIC FIELDS, 80MHZ TO 1GHZ.....	21
6.3.1 <i>E.U.T. Operation</i> .....	21
6.3.2 <i>Block Diagram of Setup</i> .....	21
6.3.3 <i>Test Results</i> .....	22
6.4 ELECTRICAL FAST TRANSIENTS (EFT) .....	23
6.4.1 <i>E.U.T. Operation</i> .....	23
6.4.2 <i>Block Diagram of Setup</i> .....	23
6.4.3 <i>Test Results</i> .....	24
6.5 SURGE.....	25
6.5.1 <i>E.U.T. Operation</i> .....	25
6.5.2 <i>Block Diagram of Setup</i> .....	25
6.5.3 <i>Test Results</i> .....	26
6.6 INJECTED CURRENTS IMMUNITY, 0.15MHZ TO 230MHZ .....	27



6.6.1	<i>E.U.T. Operation</i> .....	27
6.6.2	<i>Block Diagram of Setup</i> .....	27
6.6.3	<i>Test Results</i> .....	28
6.7	VOLTAGE DIPS AND INTERRUPTIONS .....	29
6.7.1	<i>E.U.T. Operation</i> .....	29
6.7.2	<i>Block Diagram of Setup</i> .....	29
6.7.3	<i>Test Results</i> .....	30
<b>7</b>	<b>PHOTOGRAPHS – TEST SETUP</b> .....	<b>31</b>
7.1	PHOTOGRAPH – MAINS TERMINAL DISTURBANCE VOLTAGE TEST SETUP .....	31
7.2	PHOTOGRAPH – RADIATED DISTURBANCE TEST SETUP, 30MHZ TO 1GHZ .....	31
7.3	PHOTOGRAPH – ESD IMMUNITY TEST SETUP .....	32
7.4	PHOTOGRAPH – RADIO-FREQUENCY ELECTROMAGNETIC FIELDS IMMUNITY TEST SETUP .....	32
7.5	PHOTOGRAPH – EFT IMMUNITY TEST SETUP .....	33
7.6	PHOTOGRAPH – SURGE IMMUNITY TEST SETUP .....	33
7.7	PHOTOGRAPH – INJECTED CURRENTS IMMUNITY TEST SETUP .....	34
7.8	PHOTOGRAPH – VOLTAGE DIPS AND INTERRUPTIONS IMMUNITY TEST SETUP .....	34
<b>8</b>	<b>PHOTOGRAPHS – CONSTRUCTIONAL DETAILS</b> .....	<b>35</b>
8.1	EUT – EXTERNAL VIEW.....	35

# WALTEK



### 3 General Information

#### 3.1 General Description of E.U.T.

**Product Name** ..... : Hair clipper

**Model No.** ..... : HC-W058, HC-W056, HC-W052, HC-W037, HC-W030, HC-W012, HC-W003A, TS7800, HC-W050, HC-W051, HC-W018, HC-W017, HC-W059, HC-W031, HC-W028, HC-W029, HC-W053

**Remark**..... : All models have the same circuit diagram and internal construction, only different in model names.  
Therefore the applicable tests were performed on model HC-W056.

#### 3.2 Details of E.U.T.

**Technical Data** ..... : Charging Voltage: 5Vdc, Working Voltage: Battery 3.7V

#### 3.3 Description of Support Units

The EUT has been tested as an independent unit. HC-W056 is the test sample. The DV&RE tests were performed in the condition of AC 240V/50Hz input. The other tests were performed in the condition of AC 230V/50Hz input. All AC input tests were carried out with an adapter specified by laboratory. And the RE,ESD&RS tests were performed in the additional condition of battery 3.7V.

#### 3.4 Standards Applicable for Testing

The tests were performed according to following standards:

EN IEC 55014-1:2021 Electromagnetic compatibility-Requirements for household appliances, electric tools and similar apparatus-Part 1:Emission

EN IEC 55014-2:2021 Electromagnetic compatibility-Requirements for household appliances, electric tools and similar apparatus-Part 2: Immunity Product Family Standard.



### 3.5 Test Facility

The test facility has a test site registered with the following organizations:

- **ISED – Registration No.: 21895**

Waltek Testing Group (Foshan) Co., Ltd. has been registered and fully described in a report filed with the Innovation, Science and Economic Development Canada (ISED). The acceptance letter from the ISED is maintained in our files. Registration ISED number: 21895, March 12, 2019

- **FCC – Registration No.: 820106**

Waltek Testing Group (Foshan) Co., Ltd. EMC Laboratory has been registered and fully described in a report filed with the (FCC) Federal Communications Commission. The acceptance letter from the FCC is maintained in our files. Registration 820106, August 16, 2018

- **NVLAP – Lab Code: 600191-0**

Waltek Testing Group (Foshan) Co., Ltd. EMC Laboratory is accredited by the National Voluntary Laboratory Accreditation Program (NVLAP/NIST). NVLAP Code: 600191-0.

This report must not be used by the client to claim product certification, approval, or endorsement by NVLAP, NIST, or any agency of the Federal Government.

### 3.6 Subcontracted

Whether parts of tests for the product have been subcontracted to other labs:

Yes  No

If Yes, list the related test items and lab information:

Test items:---

Lab information:---

### 3.7 Abnormalities from Standard Conditions

None.



#### 4 Equipment Used during Test

<input type="checkbox"/> Mains Terminal Disturbance Voltage (Conducted Emission) 1#					
Item	Equipment	Manufacturer	Model No.	Serial No.	Calibration Status
1.	EMI Test Receiver	R&S	ESR3	102423	Valid
2.	LISN	R&S	ENV216	101343	Valid
3.	Cable 7	HUBER+SUHNER	CBL2-NN-6M	223NN624	Valid
4.	Switch	CD	RSU-A4 18G	RSUA4008	Valid
<input checked="" type="checkbox"/> Mains Terminal Disturbance Voltage (Conducted Emission) 2#					
Item	Equipment	Manufacturer	Model No.	Serial No.	Calibration Status
1.	EMI Test Receiver	R&S	ESCI	101178	Valid
2.	LISN	R&S	ENV216	101215	Valid
3.	Cable 1	HUBER+SUHNER	CBL2-NN-6M	6102701	Valid
4.	Switch	ESE	RSU/M2	---	Valid
<input type="checkbox"/> Mains Terminal Disturbance Voltage (Conducted Emission) 3#					
Item	Equipment	Manufacturer	Model No.	Serial No.	Calibration Status
1.	EMI Test Receiver	R&S	ESR3	102842	Valid
2.	LISN	R&S	ENV216	101542	Valid
3.	Cable 12	YIHENG	LMR195UF-NMNM-2.5	---	Valid
4.	Manual RF Switch	YIHENG	SW-2	RSU0402	Valid
<input type="checkbox"/> Discontinuous Disturbance					
Item	Equipment	Manufacturer	Model No.	Serial No.	Calibration Status
1.	Discontinues Disturbance Analyzer	TESEQ	DIA1512D	28302	Valid
2.	LISN	SCHWARZBECK	NSLK 8128	8128-289	Valid
<input checked="" type="checkbox"/> Radiated Disturbance (30MHz to 1GHz) 1#					
Item	Equipment	Manufacturer	Model No.	Serial No.	Calibration Status
1.	3m Semi-anechoic Chamber	CHANGCHUANG	9m×6m×6m	---	Valid
2.	EMI Test Receiver	R&S	ESR7	101566	Valid
3.	Trilog Broadband Antenna	SCHWARZBECK	VULB 9162	9162-117	Valid
4.	Coaxial Cable (below 1GHz)	HUBER+SUHNER	CBL3-NN-12+3m	214NN320	Valid
<input type="checkbox"/> Radiated Disturbance (30MHz to 1GHz) 1#					
Item	Equipment	Manufacturer	Model No.	Serial No.	Calibration Status
1.	3m Semi-anechoic Chamber	YIHENG	9m×6m×6m	YH2021071801	Valid
2.	EMI Test Receiver	R&S	ESR7	102454	Valid
3.	Trilog Broadband Antenna	SCHWARZBECK	VULB 9163	01418	Valid
4.	Coaxial Cable (below 1GHz)	YIHENG	LMR240UF-NMSM-7.5	---	Valid



<input checked="" type="checkbox"/> ESD					
Item	Equipment	Manufacturer	Model No.	Serial No.	Calibration Status
1.	ESD Simulator	TESEQ	NSG437	521	Valid
<input checked="" type="checkbox"/> EFT & Voltage Dips and Interruptions					
Item	Equipment	Manufacturer	Model No.	Serial No.	Calibration Status
1.	EMS test system	TESEQ	NSG3040	1858	Valid
<input checked="" type="checkbox"/> Surge					
Item	Equipment	Manufacturer	Model No.	Serial No.	Calibration Status
1.	Surge Simulator	TESEQ	NSG3060	1395	Valid
<input checked="" type="checkbox"/> Injected Currents					
Item	Equipment	Manufacturer	Model No.	Serial No.	Calibration Status
1.	Conducted Immunity test system	TESEQ	NSG4070	45345	Valid
2.	CDN	TESEQ	CDN M016	31586	Valid
3.	6dB Attenuator	TESEQ	ATN6075	32122	Valid
<input checked="" type="checkbox"/> Radio-frequency Electromagnetic Fields					
Item	Equipment	Manufacturer	Model No.	Serial No.	Calibration Status
1.	RF Power Amplifier	OPHIR	5225R	1051/1712	Valid
2.	RF Power Amplifier	OPHIR	5293RE	1051/171	Valid
3.	Stacked double logarithmic periodic antenna	SCHWARZBECK	STLP9128E-SPECIAL	142	Valid
4.	Stacked double logarithmic periodic antenna	SCHWARZBECK	STLP 9149	476	Valid
5.	Analog signal generator	RS	SMB100A	105566	Valid
6.	Power meter	RS	NRP6A	101133	Valid
7.	Power meter	RS	NRP6A	101134	Valid

: Not Used

: Used



#### 4.1 Software List

Description	Manufacturer	Model	Version
EMI Test Software (Conducted Disturbance 1#)	FARATRONIC	EZ-EMC	EMEC-3A1
EMI Test Software (Conducted Disturbance 2#)	FARATRONIC	EZ-CON	FARAD-3A1.1+
EMI Test Software (Conducted Disturbance 3#)	FARATRONIC	EZ-EMC	EMC-CON 3A1.1+
EMI Test Software (Radiated Disturbance 1#)	FARATRONIC	EZ-EMC	RA-03A1-2
EMI Test Software (Radiated Disturbance 2#)	FARATRONIC	EZ-EMC	RA-03A1-2
Radiated Immunity Test Software	Chinese EMC	EMS	V1.0.0.0
Click Test Software	SCHAFFNER	DIS9966	V2.5

#### 4.2 Measurement Uncertainty

Test Item	Frequency Range	Uncertainty	Note
Conducted Emission	150kHz~30MHz	±2.6dB	(1)
Radiated Disturbance	30MHz~1GHz	±4.5dB	(1)

(1) This uncertainty represents an expanded uncertainty expressed at approximately the 95% confidence level using a coverage factor of  $k=2$ .

#### 4.3 Special Accessories and Auxiliary Equipment

Item	Equipment	Technical Data	Manufacturer	Model No.
1.	Adaptor	Input:100-240V~50/60Hz, 0.75A Output: 5Vdc/2A, 9Vdc/2A, 10Vdc/2.25A Max	HUAWEI	HW-100225C00

#### 4.4 Decision Rule

Compliance or non-compliance with a disturbance limit shall be determined in the following manner.

**If  $U_{LAB}$  is less than or equal to  $U_{cispr}$ , then**

-Compliance is deemed to occur if no measured disturbance level exceeds the disturbance limit;

-Non-compliance is deemed to occur if any measured disturbance level exceeds the disturbance limit.

**If  $U_{LAB}$  is greater than  $U_{cispr}$ , then**

-Compliance is deemed to occur if no measured disturbance level, increased by  $(U_{LAB} - U_{cispr})$ , exceeds the disturbance limit;

-Non-compliance is deemed to occur if any measured disturbance level, increased by  $(U_{LAB} - U_{cispr})$ , exceeds the disturbance limit.



## 5 Emission Test Results

### 5.1 Mains Terminals Disturbance Voltage, 150kHz to 30MHz

Test Requirement.....	: EN IEC 55014-1
Test Method.....	: EN IEC 55014-1
Test Result.....	: Pass
Frequency Range.....	: 150kHz to 30MHz
Class/Severity.....	: Table 5 of EN IEC 55014-1

#### 5.1.1 E.U.T. Operation

##### Operating Environment:

Temperature .....	: 20.8°C
Humidity.....	: 49.3%RH
Atmospheric Pressure.....	: 101.3kPa

##### EUT Operation:

Input Voltage .....	: AC 240V/50Hz
Operating Mode.....	: Specified Adapter Powered Mode

#### 5.1.2 Block Diagram of Test Setup

The Mains Terminals Disturbance Voltage tests were performed in accordance with the EN IEC 55014-1.

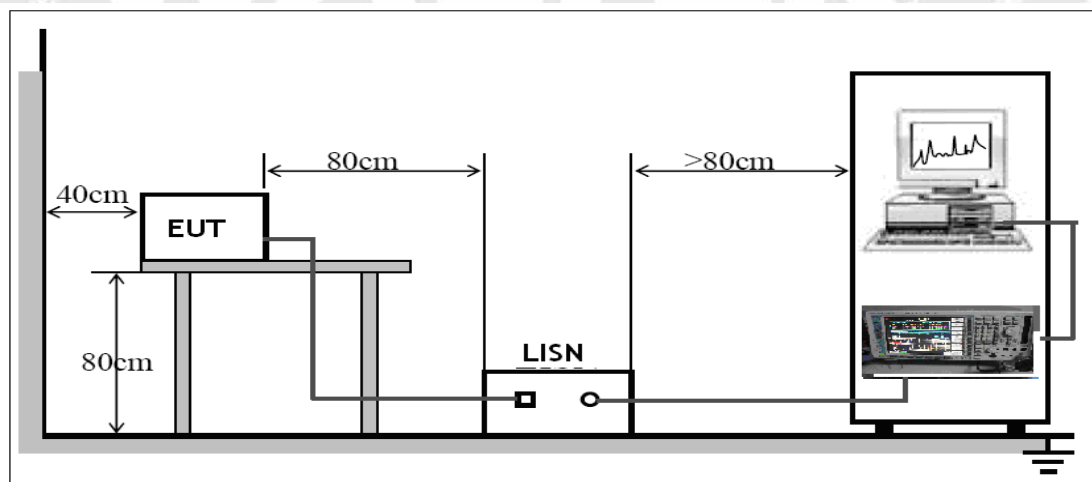

#### 5.1.3 Measurement Data

The maximised peak emissions from the EUT was scanned and measured for both the Live and Neutral Lines. Quasi-peak & average measurements were performed if peak emissions were within 6dB of the average limit line.



### 5.1.4 Corrected Amplitude & Margin Calculation

The Corrected factor is calculated by adding LISN VDF(Voltage Division Factor), Cable Loss and Transient Limiter Attenuation. The basic equation is as follows:

$$\text{Measurement} = \text{Reading Level} + \text{Correct Factor}$$

$$\text{Correct Factor} = \text{LISN VDF} + \text{Cable Loss}$$

The “Margin” column of the following data tables indicates the degree of compliance with the applicable limit. For example, a margin of -7dB means the emission is 7dB below the limit. The equation for margin calculation is as follows:

$$\text{Margin} = \text{Measurement} - \text{Limit}$$

### 5.1.5 Mains Terminals Disturbance Voltage Test Data

Live Line:

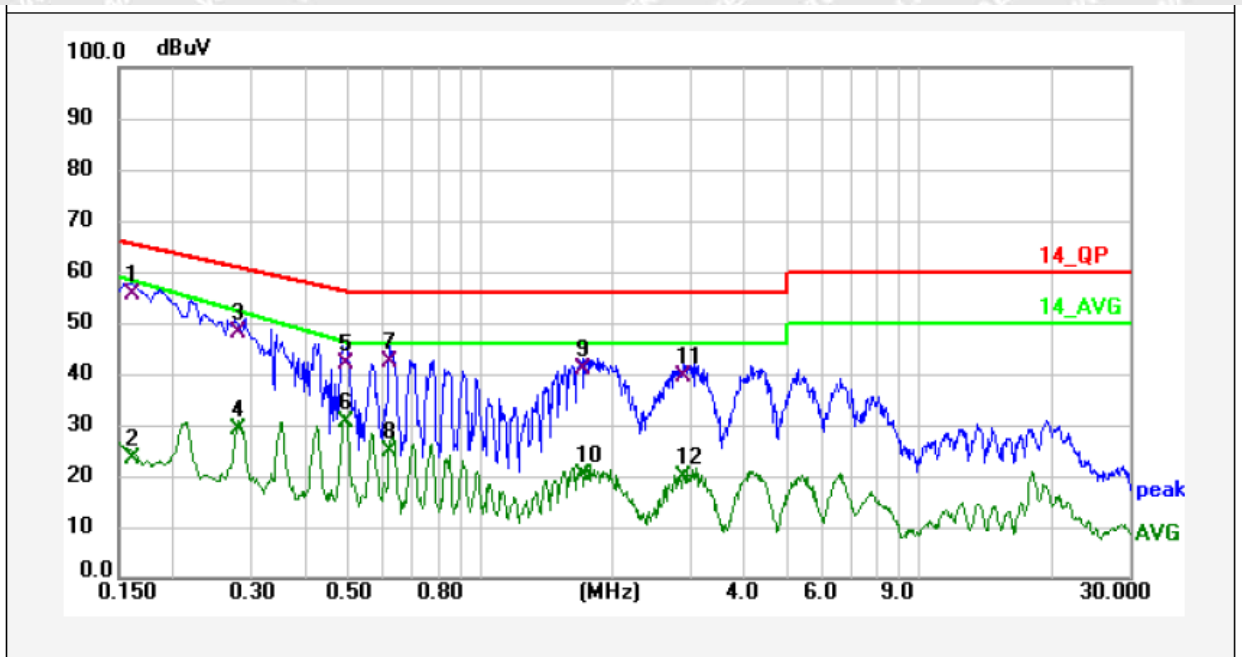

No.	Freq. (MHz)	Reading (dBuV)	Factor (dB)	Result (dBuV)	Limit (dBuV)	Margin (dB)	Detector	Remark
1	0.161	55.68	9.61	46.07	65.41	-9.73	QP	
2	0.161	23.36	9.61	13.75	58.24	-34.88	AVG	
3	0.282	48.12	9.61	38.51	60.76	-12.64	QP	
4	0.282	29.06	9.61	19.45	52.19	-23.13	AVG	
5	0.494	42.12	9.63	32.49	56.10	-13.98	QP	
6	0.494	30.48	9.63	20.85	46.13	-15.65	AVG	
7	0.622	42.36	9.65	32.71	56.00	-13.64	QP	
8	0.622	24.79	9.65	15.14	46.00	-21.21	AVG	
9	1.710	41.02	9.73	31.29	56.00	-14.98	QP	
10	1.710	20.26	9.73	10.53	46.00	-25.74	AVG	
11	2.906	39.36	9.79	29.57	56.00	-16.64	QP	
12	2.906	19.77	9.79	9.98	46.00	-26.23	AVG	



**Neutral Line:**

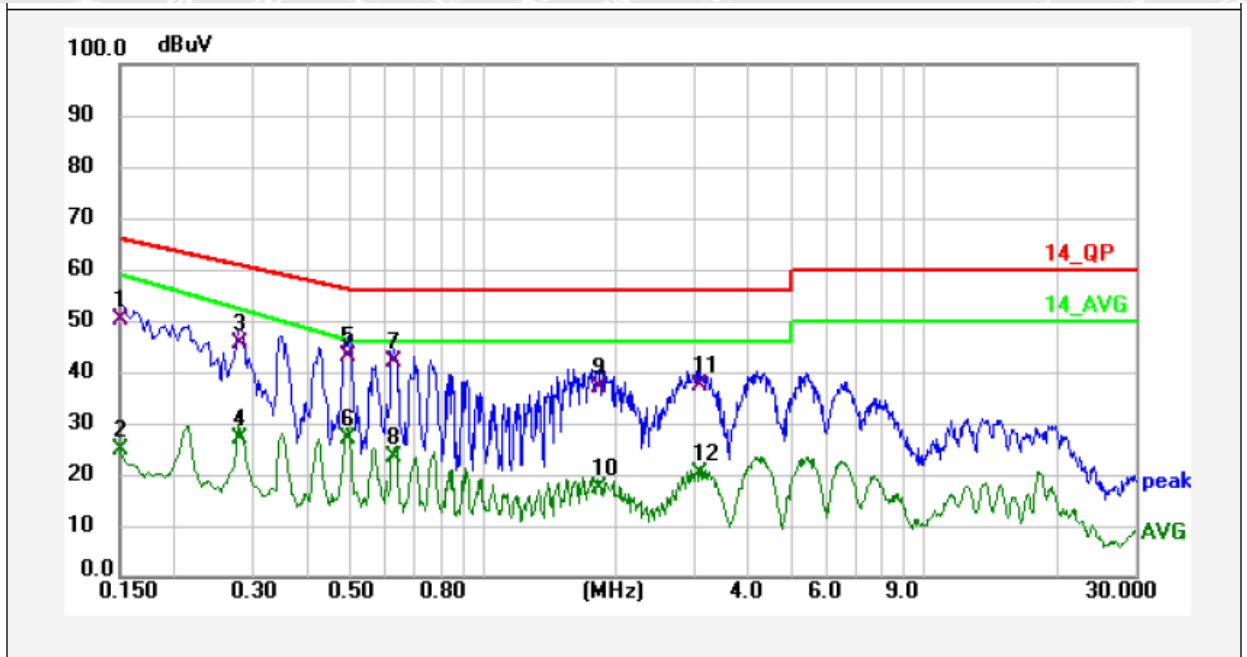

No.	Freq. (MHz)	Reading (dBuV)	Factor (dB)	Result (dBuV)	Limit (dBuV)	Margin (dB)	Detector	Remark
1	0.150	50.26	9.52	40.74	66.00	-15.74	QP	
2	0.150	24.71	9.52	15.19	59.00	-34.29	AVG	
3	0.282	45.56	9.54	36.02	60.76	-15.20	QP	
4	0.282	27.11	9.54	17.57	52.19	-25.08	AVG	
5	0.494	43.12	9.57	33.55	56.10	-12.98	QP	
6	0.494	27.08	9.57	17.51	46.13	-19.05	AVG	
7	0.626	42.02	9.58	32.44	56.00	-13.98	QP	
8	0.626	23.37	9.58	13.79	46.00	-22.63	AVG	
9	1.838	36.96	9.65	27.31	56.00	-19.04	QP	
10	1.838	17.18	9.65	7.53	46.00	-28.82	AVG	
11	3.102	37.15	9.71	27.44	56.00	-18.85	QP	
12	3.102	20.03	9.71	10.32	46.00	-25.97	AVG	



## 5.2 Radiated Disturbance, 30MHz to 1GHz

Test Requirement.....	: EN IEC 55014-1
Test Method.....	: EN IEC 55014-1
Test Result.....	: Pass
Frequency Range.....	: 30MHz to 1GHz
Class/Severity.....	: Table 9 of EN IEC 55014-1

### 5.2.1 E.U.T. Operation

#### Operating Environment:

Temperature.....	: 23.3°C
Humidity.....	: 51.6%RH
Atmospheric Pressure.....	: 101.1kPa

#### EUT Operation:

Input Voltage.....	: Refer to section 5.3.5
Operating Mode.....	: Refer to section 5.3.5

### 5.2.2 Block Diagram of Test Setup

The Radiated Disturbance test was performed in the 3m Semi- Anechoic Chamber test site and accordance with CISPR16-2-3.

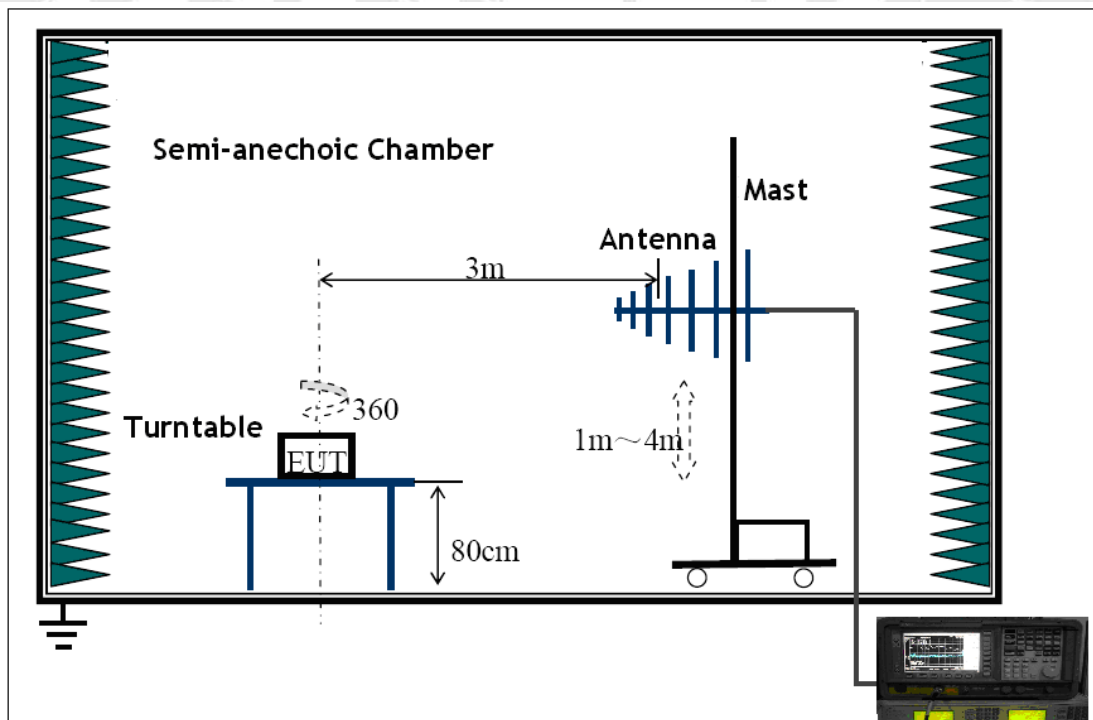

### 5.2.3 Measurement Data

The maximised peak emissions from the EUT was scanned and measured for Horizontal & Vertical polarisation. Quasi-peak measurements were performed if peak emissions were within 6dB of the limit line.



### 5.2.4 Corrected Amplitude & Margin Calculation

The Corrected Amplitude is calculated by adding the Antenna Factor and Cable Factor, and subtracting the Amplifier Gain from the Amplitude reading. The basic equation is as follows:

$$\text{Corr. Ampl.} = \text{Indicated Reading} + \text{Corr. Factor}$$

$$\text{Corr. Factor} = \text{Antenna Factor} + \text{Cable Factor} - \text{Amplifier Gain}$$

The "Margin" column of the following data tables indicates the degree of compliance with the applicable limit. For example, a margin of -7dB means the emission is 7dB below the maximum limit.

The equation for margin calculation is as follows:

$$\text{Margin} = \text{Corr. Ampl.} - \text{Limit}$$

### 5.2.5 Radiated Disturbance Test Data

**Specified Adapter Powered Mode**

**AC 240V/50Hz input**

**Vertical Polarization:**

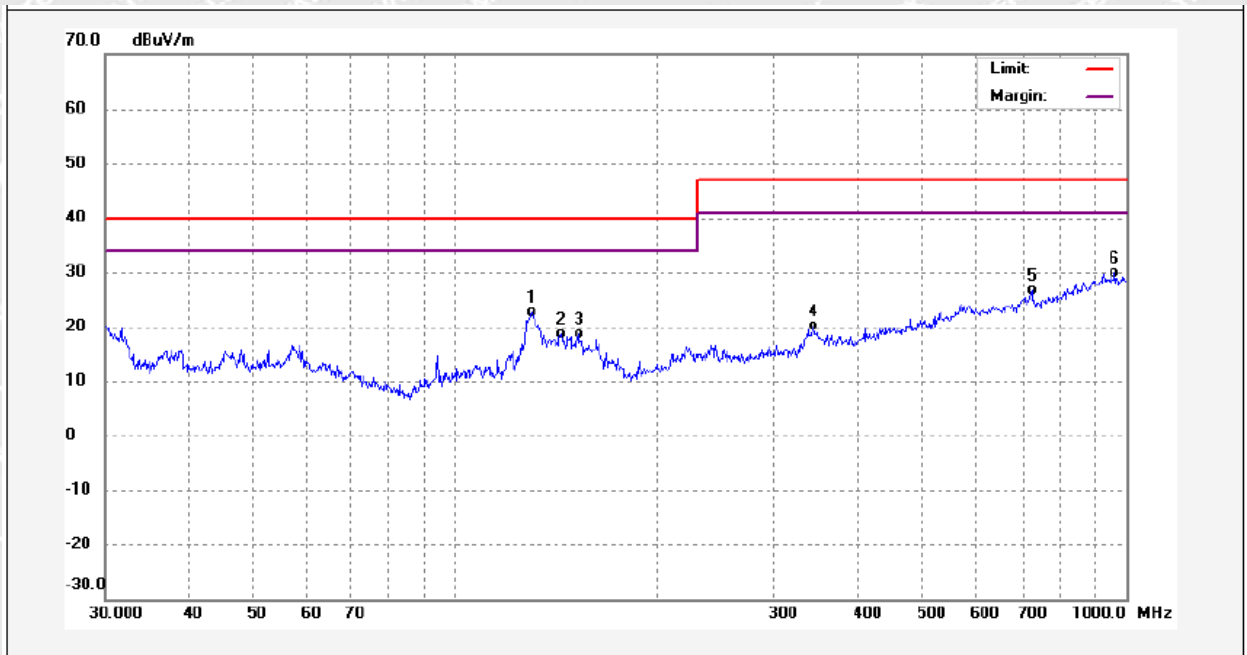

No.	Freq. (MHz)	Reading (dBuV/m)	Factor (dB)	Result (dBuV/m)	Limit (dBuV/m)	Margin (dB)	Detector	Remark
1	129.9226	12.89	9.84	22.73	40.00	-17.27	QP	
2	143.9304	9.53	9.17	18.70	40.00	-21.30	QP	
3	152.9320	8.86	9.66	18.52	40.00	-21.48	QP	
4	342.3387	3.26	16.83	20.09	47.00	-26.91	QP	
5	725.0233	2.30	24.30	26.60	47.00	-20.40	QP	
6	964.5269	2.25	27.71	29.96	47.00	-17.04	QP	



**Specified Adapter Powered Mode**

**AC 240V/50Hz input**

**Horizontal Polarization:**

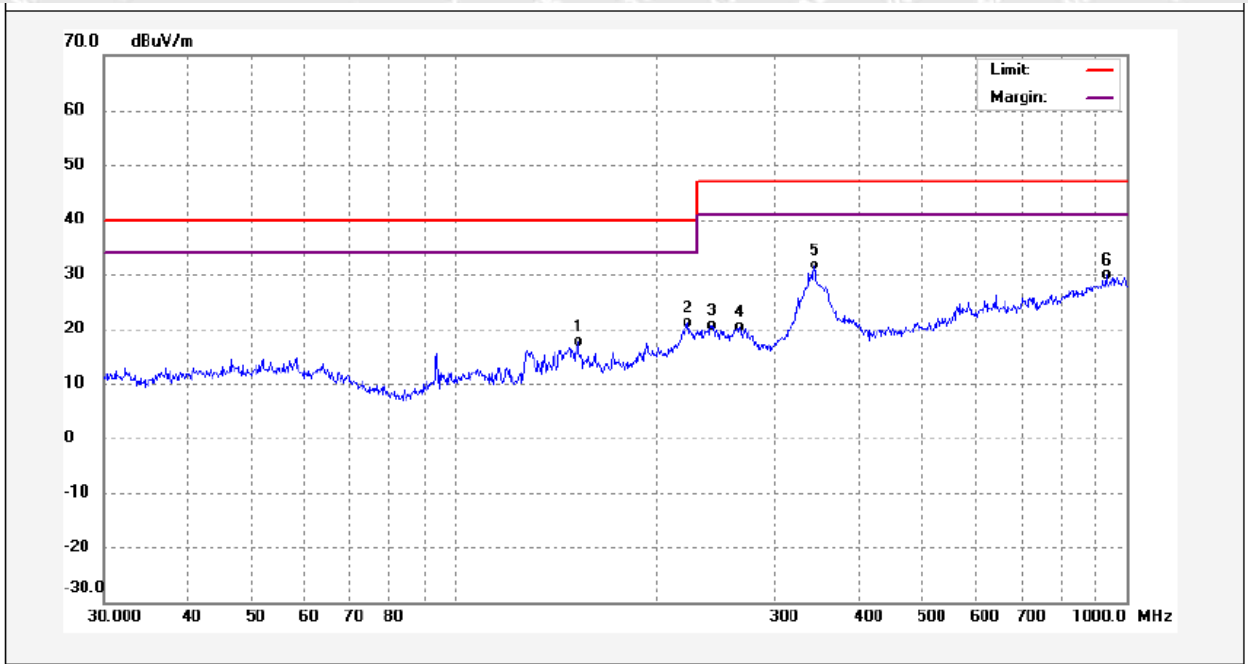

No.	Freq. (MHz)	Reading (dBuV/m)	Factor (dB)	Result (dBuV/m)	Limit (dBuV/m)	Margin (dB)	Detector	Remark
1	153.1467	7.95	9.69	17.64	40.00	-22.36	QP	
2	222.3257	6.69	14.33	21.02	40.00	-18.98	QP	
3	241.7611	6.03	14.60	20.63	47.00	-26.37	QP	
4	266.5155	5.70	14.63	20.33	47.00	-26.67	QP	
5	343.7822	14.61	16.90	31.51	47.00	-15.49	QP	
6	935.2183	2.33	27.45	29.78	47.00	-17.22	QP	



**Battery Powered Mode**

**Battery 3.7V**

**Vertical Polarization:**

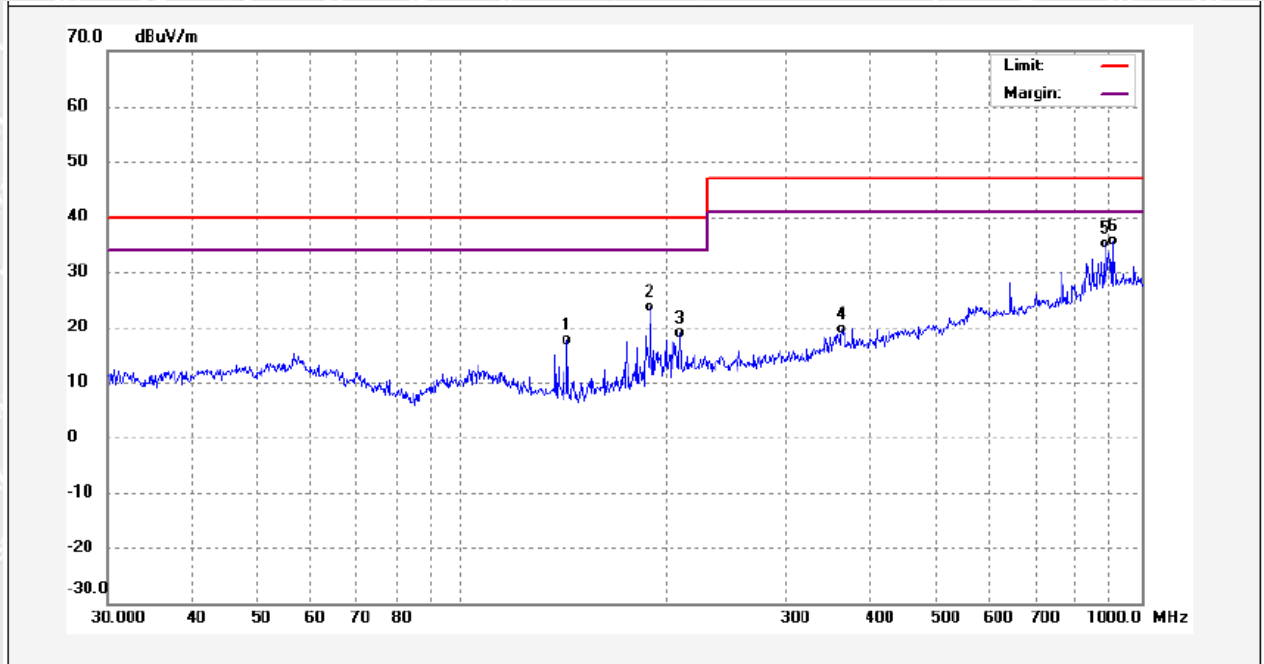

No.	Freq. (MHz)	Reading (dBuV/m)	Factor (dB)	Result (dBuV/m)	Limit (dBuV/m)	Margin (dB)	Detector	Remark
1	142.9246	8.48	9.12	17.60	40.00	-22.40	QP	
2	189.1407	11.49	12.04	23.53	40.00	-16.47	QP	
3	209.6802	5.55	13.30	18.85	40.00	-21.15	QP	
4	361.9675	1.89	17.84	19.73	47.00	-27.27	QP	
5	884.1928	8.93	26.30	35.23	47.00	-11.77	QP	
6	906.4824	8.96	26.73	35.69	47.00	-11.31	QP	



**Battery Powered Mode**

**Battery 3.7V**

**Horizontal Polarization:**

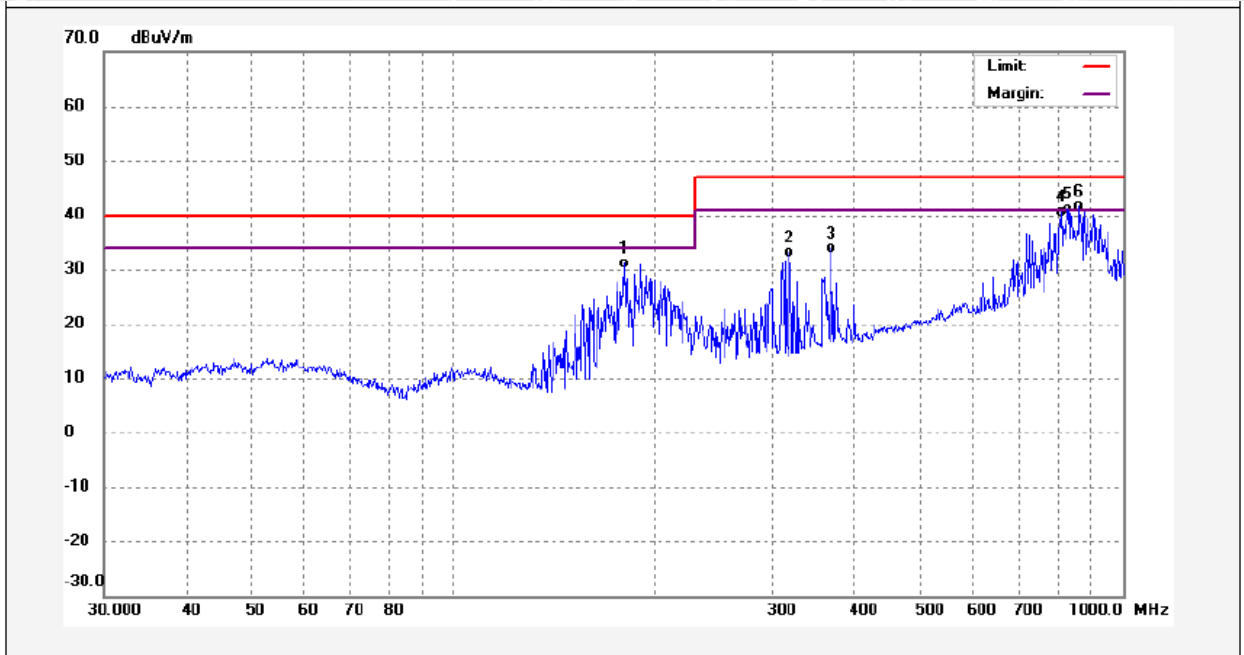

No.	Freq. (MHz)	Reading (dBuV/m)	Factor (dB)	Result (dBuV/m)	Limit (dBuV/m)	Margin (dB)	Detector	Remark
1	180.4589	19.98	11.14	31.12	40.00	-8.88	QP	
2	317.8125	17.24	15.78	33.02	47.00	-13.98	QP	
3	367.4668	15.91	17.91	33.82	47.00	-13.18	QP	
4	808.2789	14.98	25.56	40.54	47.00	-6.46	QP	
5	828.9455	14.86	26.32	41.18	47.00	-5.82	QP	
6	862.1488	15.56	26.15	41.71	47.00	-5.29	QP	



## 6 Immunity Test Results

### 6.1 Performance Criteria

**Performance criterion A:** The apparatus shall continue to operate as intended during the test. No degradation of performance or loss of function is allowed below a performance level (or permissible loss of performance) specified by the manufacturer, when the apparatus is used as intended. If the minimum performance level or the permissible performance loss is not specified by the manufacturer, then either of these may be derived from the product description and documentation, and from what the user may reasonably expect from the apparatus if used as intended.

**Performance criterion B:** The apparatus shall continue to operate as intended after the test. No degradation of performance or loss of function is allowed below a performance level (or permissible loss of performance) specified by the manufacturer, when the apparatus is used as intended. During the test, degradation of performance is allowed, however, no change of actual operating state or stored data is allowed. If the minimum performance level or the permissible performance loss is not specified by the manufacturer, then either of these may be derived from the product description and documentation, and from what the user may reasonably expect from the apparatus if used as intended.

**Performance criterion C:** Temporary loss of function is allowed, provided the function is self-recoverable or can be restored by the operation of the controls, or by any operation specified in the instructions for use. For further details, please refer to EN IEC 55014-2.

# WALTEK



## 6.2 Electrostatic Discharge (ESD)

<b>Test Requirement</b> .....	:	EN IEC 55014-2
<b>Test Method</b> .....	:	IEC 61000-4-2
<b>Test Result</b> .....	:	Pass
<b>Discharge Impedance</b> .....	:	330Ω / 150pF
<b>Discharge Voltage</b> .....	:	Air Discharge: ±8kV Contact Discharge: ±4kV HCP & VCP: ±4kV
<b>Polarity</b> .....	:	Positive & Negative
<b>Number of Discharge</b> .....	:	Minimum 10 times at each test point
<b>Discharge Mode</b> .....	:	Single Discharge
<b>Discharge Period</b> .....	:	1 second minimum

### 6.2.1 E.U.T. Operation

#### Operating Environment:

<b>Temperature</b> .....	:	21.1°C
<b>Humidity</b> .....	:	51.8%RH
<b>Barometric Pressure</b> .....	:	100.9kPa

#### EUT Operation:

<b>Input Voltage</b> .....	:	AC 230V/50Hz, Battery 3.7V
<b>Operating Mode</b> .....	:	On mode

### 6.2.2 Block Diagram of Setup

The ESD test was performed in accordance with the IEC 61000-4-2.

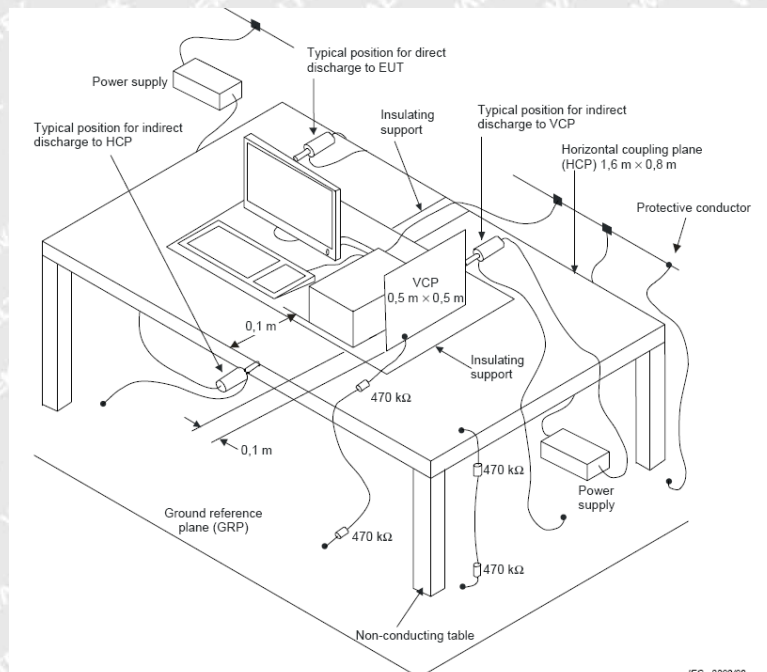





### 6.3 Radio-Frequency Electromagnetic Fields, 80MHz to 1GHz

<b>Test Requirement</b> .....	:	EN IEC 55014-2
<b>Test Method</b> .....	:	IEC 61000-4-3
<b>Test Result</b> .....	:	Pass
<b>Frequency Range</b> .....	:	80MHz to 1GHz
<b>Test level</b> .....	:	3V/m
<b>Modulation</b> .....	:	80%, 1kHz Amplitude Modulation.
<b>Face of EUT</b> .....	:	Front, Back, Left, Right
<b>Antenna polarisation</b> .....	:	Horizontal & Vertical
<b>Test Distance</b> .....	:	3m

#### 6.3.1 E.U.T. Operation

##### Operating Environment:

<b>Temperature</b> .....	:	23.3°C
<b>Humidity</b> .....	:	51.6% RH
<b>Barometric Pressure</b> .....	:	101.4kPa

##### EUT Operation:

<b>Input Voltage</b> .....	:	Battery 3.7V
<b>Operating Mode</b> .....	:	On mode

#### 6.3.2 Block Diagram of Setup

The Radio-Frequency Electromagnetic Fields Immunity test was performed in accordance with the IEC 61000-4-3.

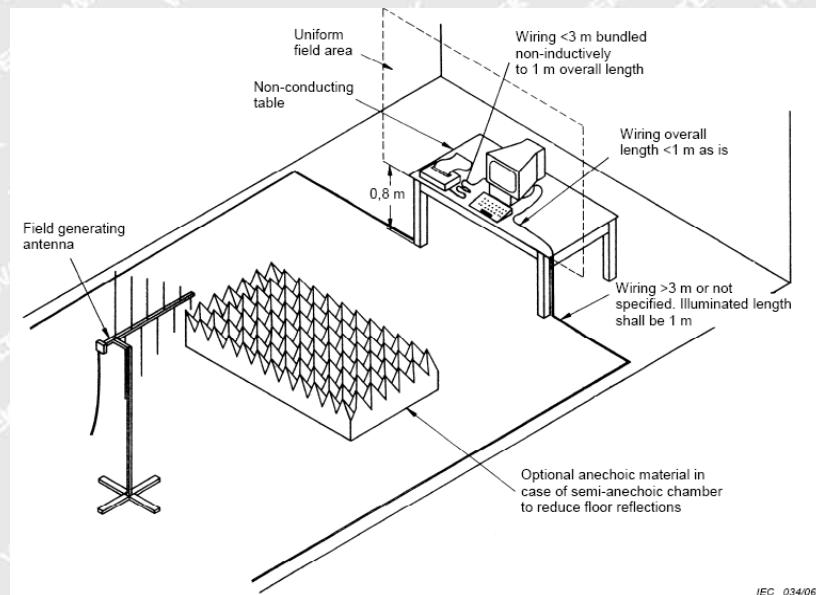



### 6.3.3 Test Results

Frequency	Face of EUT	Antenna polarisation	Test Level	Step Size	Dwell Time	Performance Criterion	Result
80 to 1000MHz	Front, Back, Left, Right	Horizontal	3V/m	1%	1s	A	Pass*
80 to 1000MHz	Front, Back, Left, Right	Vertical	3V/m	1%	1s	A	Pass*

Remark:

\* During the test no deviation was detected to the selected operation mode(s)

# WALTEK



## 6.4 Electrical Fast Transients (EFT)

<b>Test Requirement</b> .....	: EN IEC 55014-2
<b>Test Method</b> .....	: IEC 61000-4-4
<b>Test Result</b> .....	: Pass
<b>Test Level</b> .....	: 1.0kV on AC Mains
<b>Polarity</b> .....	: Positive & Negative
<b>Repetition Frequency</b> ....	: 5kHz
<b>Burst Duration</b> .....	: 300ms
<b>Test Duration</b> .....	: 2 minutes per level & polarity

### 6.4.1 E.U.T. Operation

#### Operating Environment:

<b>Temperature</b> .....	: 21.4°C
<b>Humidity</b> .....	: 51.9%RH
<b>Barometric Pressure</b> .....	: 100.9kPa

#### EUT Operation:

<b>Input Voltage</b> .....	: AC 230V/50Hz
<b>Operating Mode</b> .....	: On mode

### 6.4.2 Block Diagram of Setup

The Electrical Fast Transients Immunity test was performed in accordance with the IEC 61000-4-4.

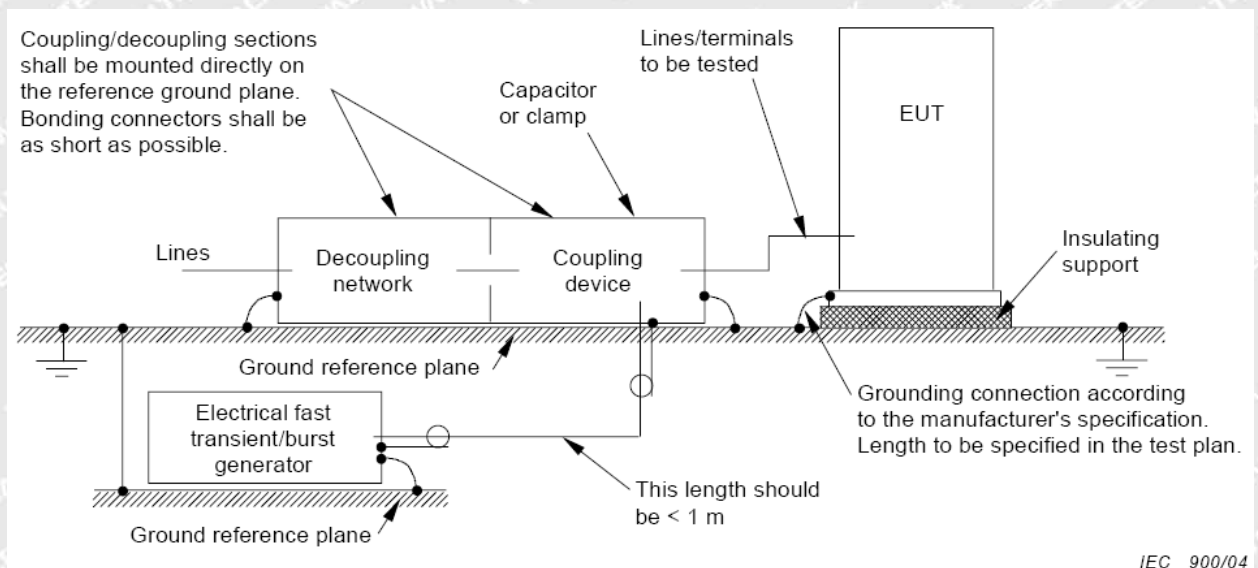



### 6.4.3 Test Results

Test Port	Test Level(kV)	Performance Criterion	Result
Line-Neutral	$\pm 1.0$	B	Pass*

Remark:

- \* During the test no deviation was detected to the selected operation mode(s)

# WALTEK



## 6.5 Surge

<b>Test Requirement</b> .....	:	EN IEC 55014-2
<b>Test Method</b> .....	:	IEC 61000-4-5
<b>Test Result</b> .....	:	Pass
<b>Test level</b> .....	:	±1kV Live to Neutral, ±2kV Live to PE and Neutral to PE
<b>Interval</b> .....	:	60s between each surge
<b>No. of surges</b> .....	:	5 positive at 90°, 5 negative at 270°.

### 6.5.1 E.U.T. Operation

#### Operating Environment:

<b>Temperature</b> .....	:	21.2°C
<b>Humidity</b> .....	:	52.3%RH
<b>Barometric Pressure</b> .....	:	100.9kPa

#### EUT Operation:

<b>Input Voltage</b> .....	:	AC 230V/50Hz
<b>Operating Mode</b> .....	:	On mode

### 6.5.2 Block Diagram of Setup

The Surge Immunity test was performed in accordance with the IEC 61000-4-5.

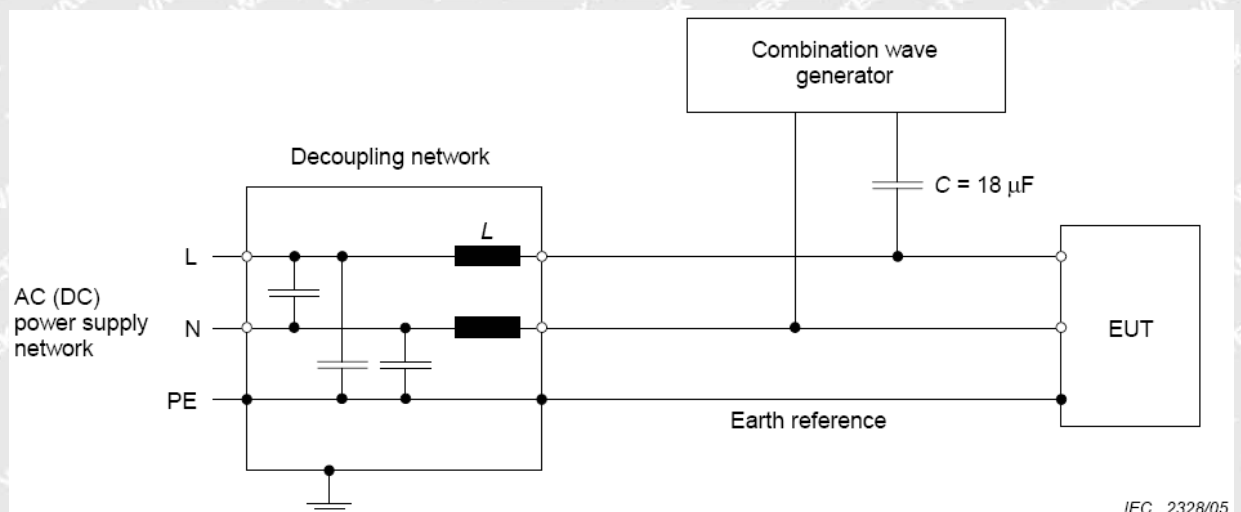



### 6.5.3 Test Results

Test Port	Applied Voltage (kV)	Performance criterion	Result
Between Phase And Phase	$\pm 1$	B	N/A
Between Live And Neutral	$\pm 1$	B	Pass*
Between Live And Earth	$\pm 2$	B	N/A
Between Neutral And Earth	$\pm 2$	B	N/A

Remark:

- \* During the test no deviation was detected to the selected operation mode(s)

# WALTEK



## 6.6 Injected Currents Immunity, 0.15MHz to 230MHz

Test Requirement .....	: EN IEC 55014-2
Test Method .....	: IEC 61000-4-6
Test Result .....	: Pass
Frequency Range .....	: 0.15MHz to 230MHz
Test level .....	: 3V r.m.s. (unmodulated emf into 150 $\Omega$ )
Modulation .....	: 80%, 1kHz Amplitude Modulation.

### 6.6.1 E.U.T. Operation

#### Operating Environment:

Temperature .....	: 21.5°C
Humidity .....	: 51.6% RH
Barometric Pressure .....	: 100.9kPa

#### EUT Operation:

Input Voltage .....	: AC 230V/50Hz
Operating Mode .....	: On mode

### 6.6.2 Block Diagram of Setup

The Injected Currents Immunity test was performed in accordance with the IEC 61000-4-6.

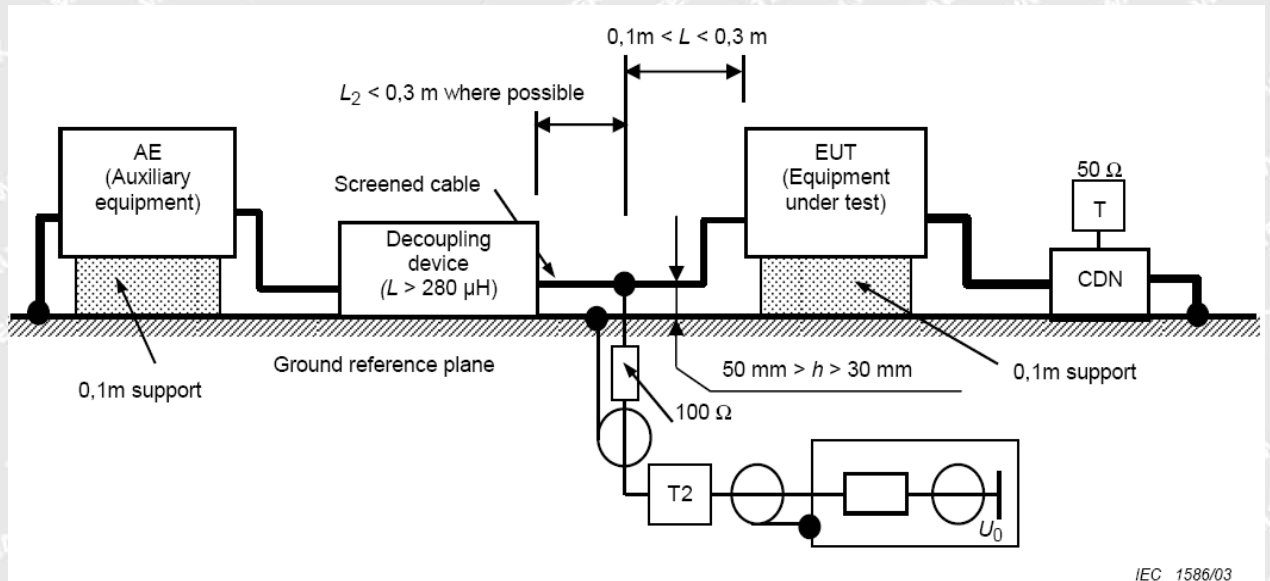



### 6.6.3 Test Results

Frequency	Line	Test Level	Modulation	Step Size	Dwell Time	Performance Criterion	Result
0.15MHz to 230MHz	2 Wire AC Supply Cables	3Vr.m.s.	80%, 1kHz Amp. Mod.	1%	1s	A	Pass*

Remark:

- \* During the test no deviation was detected to the selected operation mode(s)

# WALTEK



## 6.7 Voltage Dips and Interruptions

Test Requirement.....	:	EN IEC 55014-2
Test Method.....	:	IEC 61000-4-11
Test Result.....	:	Pass
Test Level(Voltage reduction)	:	0% & 40% & 70 % of $U_T$ (Supply Voltage)
No. of Dips / Interruptions.....	:	1 per Level at 20ms intervals

### 6.7.1 E.U.T. Operation

#### Operating Environment:

Temperature .....	:	21.2°C
Humidity.....	:	51.6%RH
Barometric Pressure.....	:	100.9kPa

#### EUT Operation:

Input Voltage .....	:	AC 230V/50Hz
Operating Mode.....	:	On mode

### 6.7.2 Block Diagram of Setup

The Voltage Dips and Interruptions Immunity test was performed in accordance with the IEC 61000-4-11.

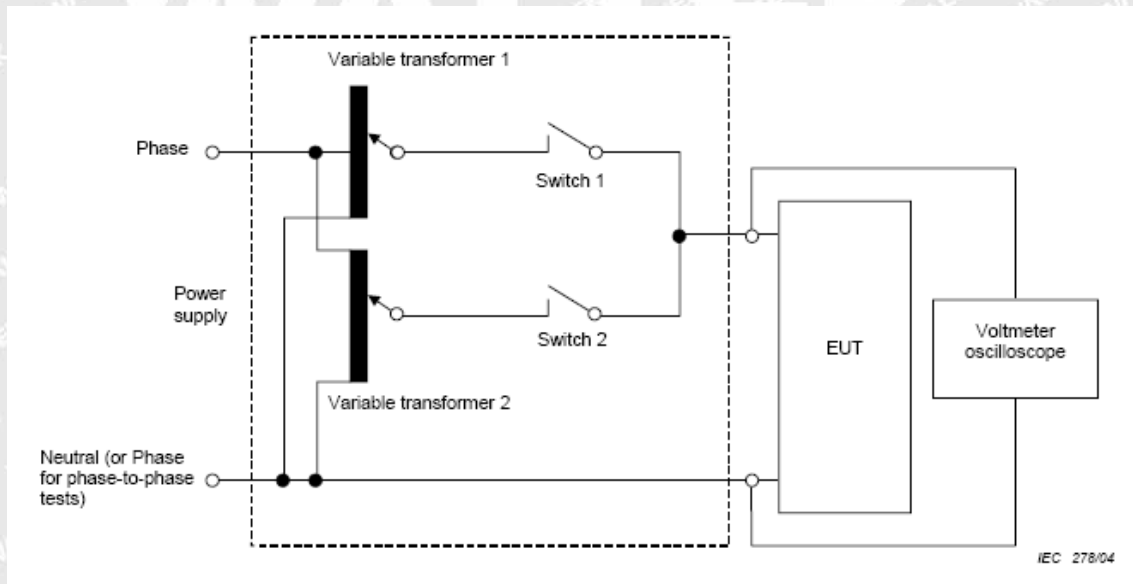



### 6.7.3 Test Results

Test Level in %U <sub>T</sub>	Performance criterion	50Hz		60Hz	
		Duration	Result	Duration	Result
0	C	0.5	Pass*	0.5	N/A
40	C	10	Pass*	12	N/A
70	C	25	Pass*	30	N/A

Remark:

\* During the test no deviation was detected to the selected operation mode(s)

# WALTEK



## 7 Photographs – Test Setup

### 7.1 Photograph – Mains Terminal Disturbance Voltage Test Setup



### 7.2 Photograph – Radiated Disturbance Test Setup, 30MHz to 1GHz





### 7.3 Photograph – ESD Immunity Test Setup

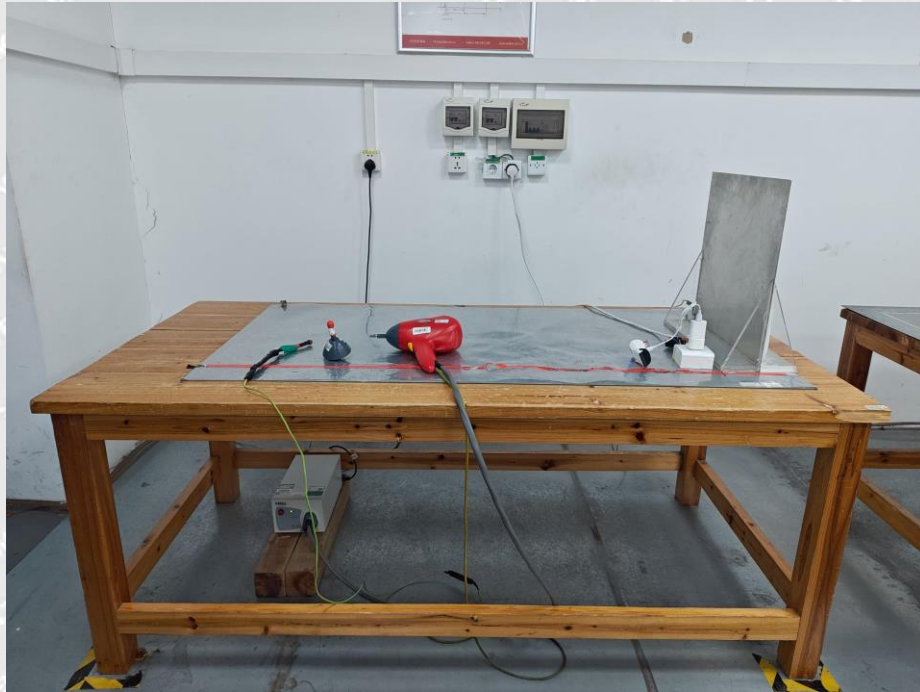

### 7.4 Photograph – Radio-Frequency Electromagnetic Fields Immunity Test Setup





### 7.5 Photograph – EFT Immunity Test Setup



### 7.6 Photograph – Surge Immunity Test Setup





### 7.7 Photograph – Injected Currents Immunity Test Setup



### 7.8 Photograph – Voltage Dips and Interruptions Immunity Test Setup





## 8 Photographs – Constructional Details

### 8.1 EUT – External View

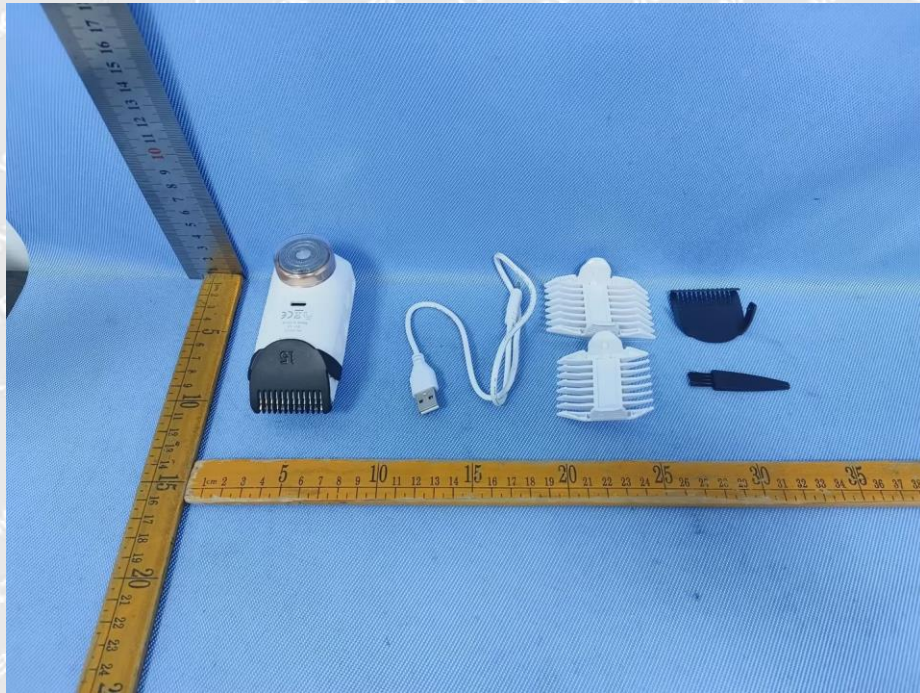

===== End of Report =====

# WALTEK